



Floating Ball Valve
Series EB - Bolted Body
Series ES - Screwed Body

TECHNICAL BULLETIN



KEY FEATURES

- ▶ Made in USA
- ▶ Buy American Act
- ▶ Made in USA
- ▶ **Progressive Seal Technology™ ***
Evolutionary Seat Design with Enhanced Ball to Seat Interface
- ▶ Forged Bodies and Adapters
- ▶ Every Valve 100% High-Pressure and Low-Pressure Tested
- ▶ Designed and tested to exceed ASME B16.34
- ▶ Advanced Actuator Mounting System Patent Pending
- ▶ Low Torques
- ▶ Robust External Stop Plate System
- ▶ Optimized Stem Shaft Drivetrain System
- ▶ Precision-Engineered Seals
- ▶ Up to CLASS 1500 ANSI Rating
- ▶ Next Generation Easy Grip handle **

EVOLUTION OF THE FLOATING BALL VALVE

EDi has revolutionized the **Floating Ball Valve** with our new Patented **Progressive Seal Technology™ *** design.

The **Original Floating Ball Valve Seat** relies upon an interference fit to compress a solid plastic seal ring. The elastic properties of the plastic resist the induced compression and provide a seal against upstream pressure.

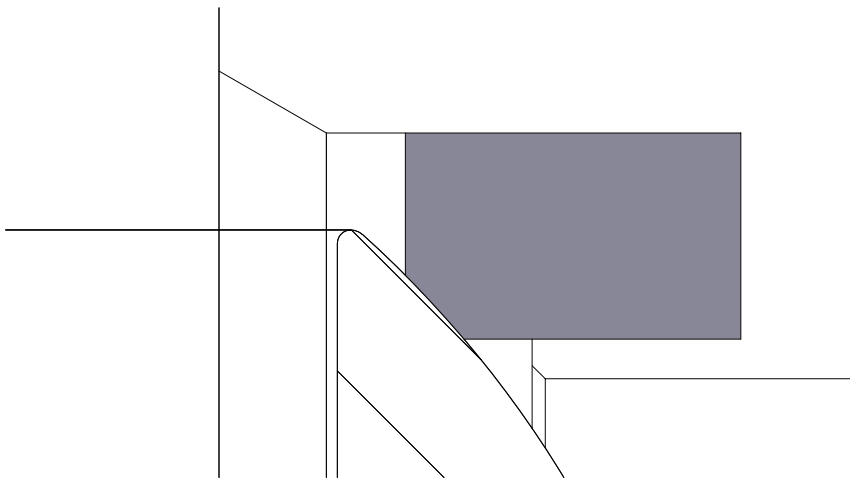

*Patent No. US 10,801,626 B2 / International DM/212755

**Patent No. US D880,658 S



Reliefs added to the **Original Floating Ball Valve Seat** design allowed the seat to react in a more spring like manner advancing seat performance and efficiency.

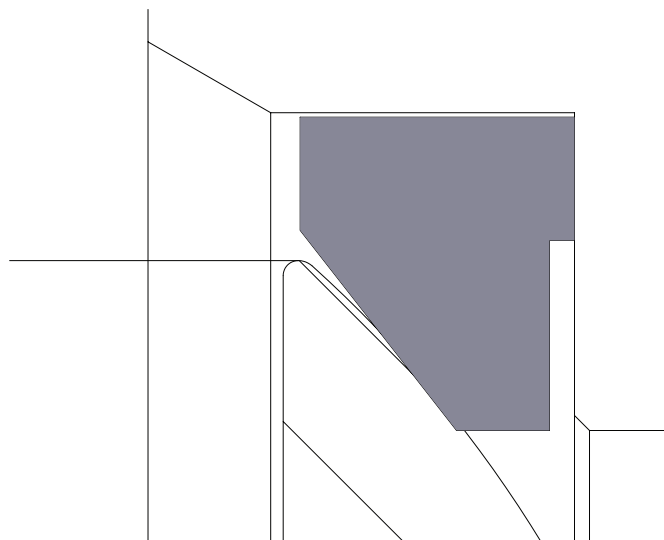

In the late 1960's the introduction of patented **Multi-Seal Technology** continued the advancement of seat design introducing auxiliary blunt edged sealing faces that provided 1 low pressure and up to 2 high pressure sealing contacts. The blunt edged auxiliary faces allowed for grooves to collect and trap particulates for removal over multiple open and close cycles.

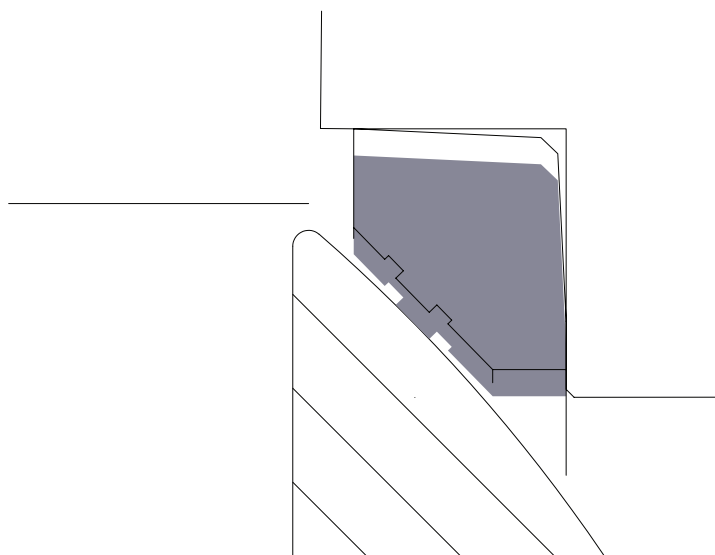

“Operational and Environmental demands challenging the Energy Industry are driving the need for an improved floating ball valve seat design that provides progressive sealing surfaces in both low and high pressure applications ”



Introducing EDi Progressive Seal Technology™ *

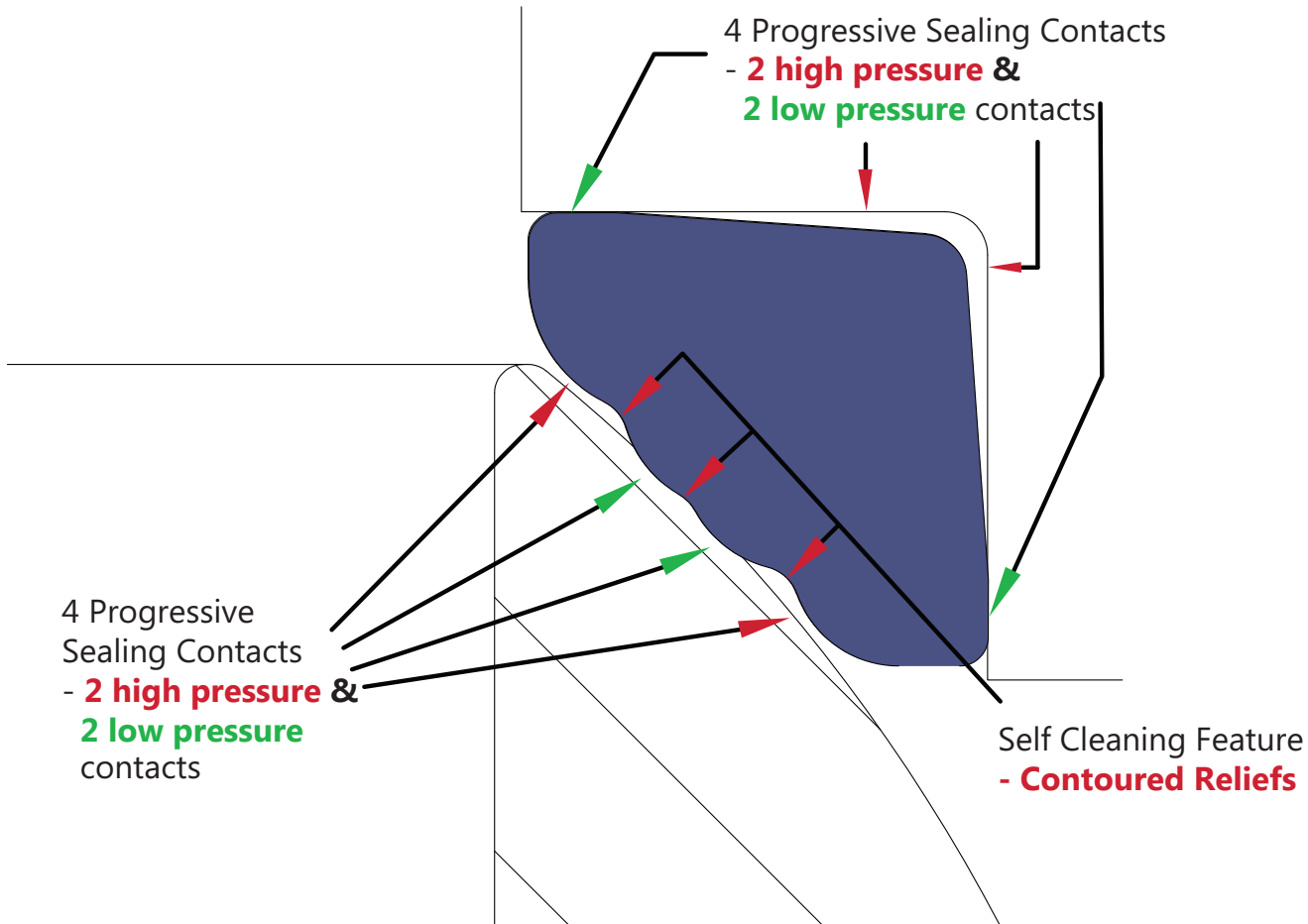

EDi's **Progressive Seal Technology™*** introduces 4 Contoured Front Sealing Faces and 4 Flat Backside Sealing Faces that dramatically improve low and high pressure bubble tight sealing in floating ball valve applications. The dynamically energized seat is designed to be self relieving on the upstream side reducing operating torques.

Seats with blunt-edge grooves can capture and retain particulate during repeated open and close cycles potentially damaging the ball surface. EDi's **Progressive Seal Technology™*** introduces 4 independent seal faces separated by contoured reliefs that ensure particulates are readily swept away during opening and closing cycles.

The 4 Flat Backside Sealing Faces protect the seat pocket from particulate by isolating the seal surface on the backside of the seat ensuring optimum seat performance and efficiency.

EDi's **Progressive Seal Technology™*** offers an evolution in sealing performance that is at the very heart of floating ball valve design. Delivering advanced sealing performance, lower torques, and enhanced operational characteristics, EDi products are at the forefront of valve innovation

*Patent No. US 10,801,626 B2 / International DM/212755



Optimized Stem Shaft Drivetrain System

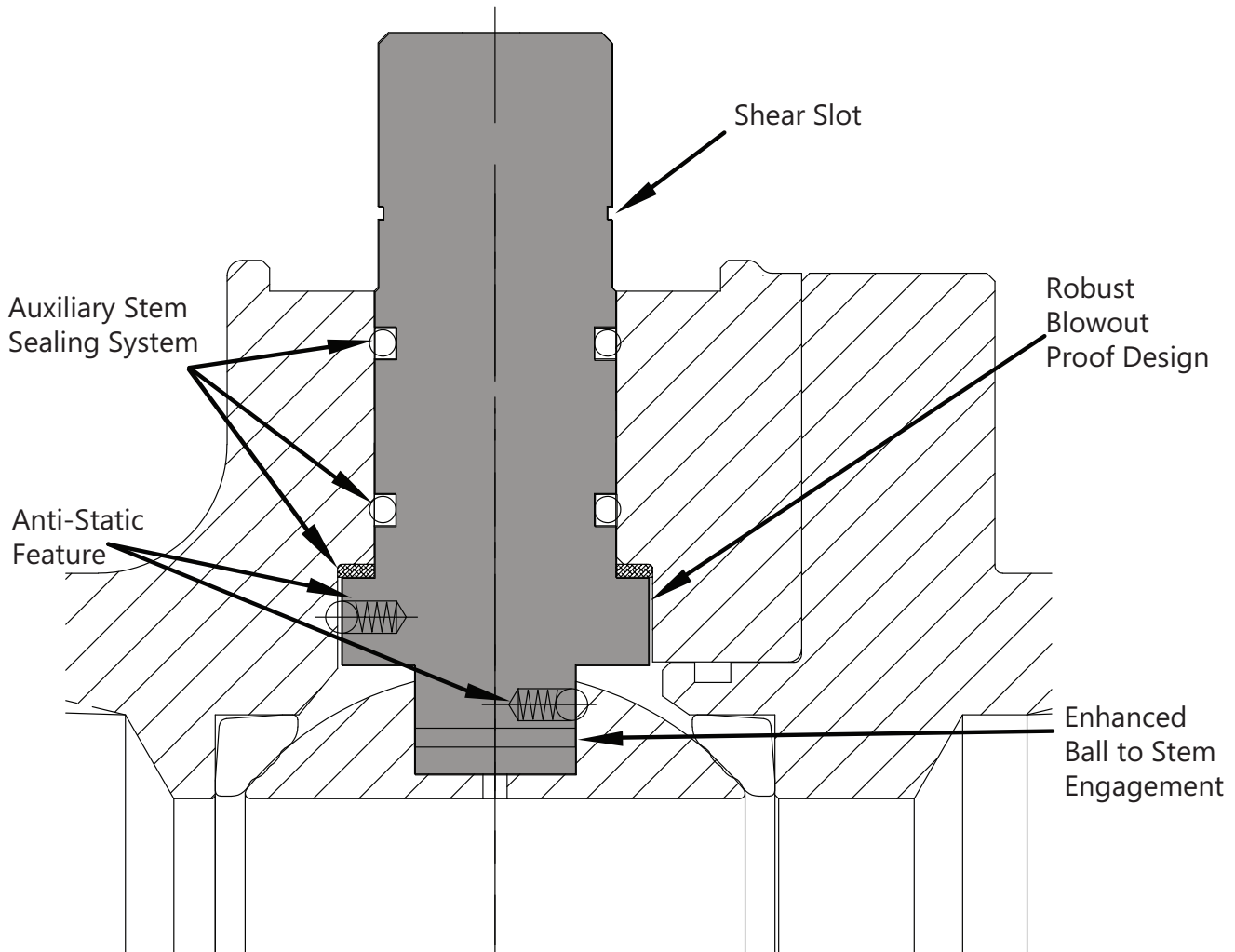

Key Features

- Extra Large Stem for strength, operation and safety
- Enhanced Ball to Stem Engagement
- Auxiliary Stem Sealing
- Integrated Safety Shear Slot
- Anti-Static feature to ensure continuity and eliminate electrostatic discharge



ADVANCED "NEVER SLIP" ACTUATOR MOUNTING SYSTEM Patent Pending

- ▶ Forged integrated Guide Rails
- ▶ Strong Torque Transmission
- ▶ Off the shelf bracketing pre-fabricated to ISO-5211
- ▶ Set it and forget it with Never Slip Design
- ▶ 100% Actuator Ready

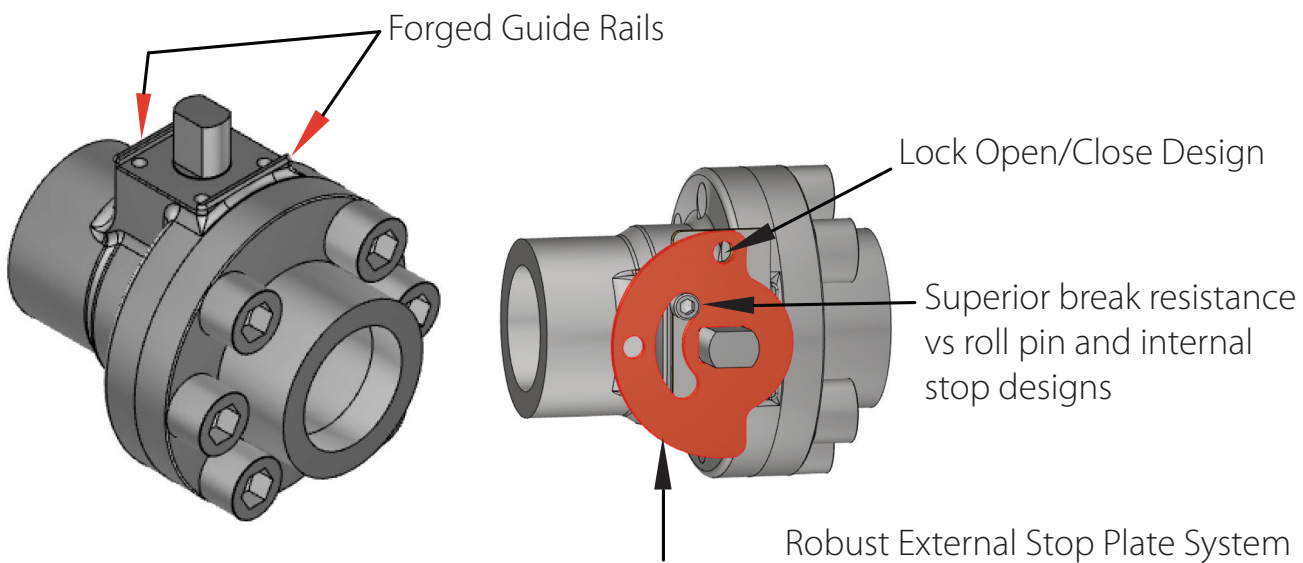

NEXT GENERATION EASY-GRIP HANDLE**

- ▶ Perfect Ergonomics for a more natural fit & support
- ▶ 4 Non-Slip, Form Fitted Gripping Points

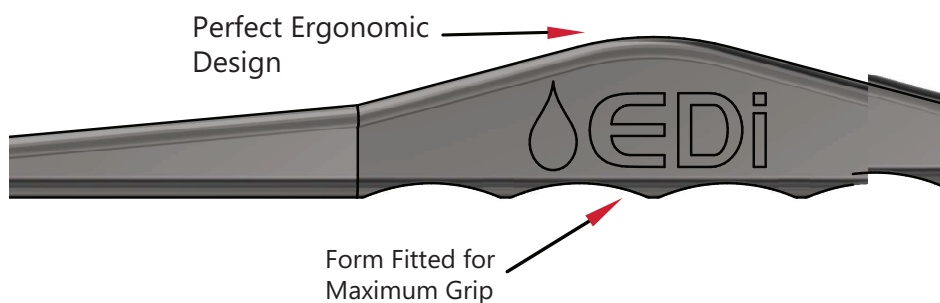

** Patent No. US D880,658 S





Design and Manufacturing Standards

Series EB & ES

Design & Manufacturing Standards	API 6D/6A/608, ASME B16.34 ASME BPVC Sec. VIII DIV 1 & 2
Pipe Thread	ANSI B1.20.1 / API-5B
Valve Bore	API 6D/608
Valve Butt-weld Ends/Socket Weld Ends	ASME B16.11
Pressure Tests	API 6D/API 598/ASME B16.34
Fire Safe Design	API 607
NACE Compliance	NACE MR-01-75 / ISO 15156
Quality System	ISO 9001-2015
Fugitive Emission Design	ISO 15848-1/API/ANSI/ISA S 93.00.01
Markings	MSS - SP - 25 / ASME B16.34

STATE-OF-THE-ART 2K PAINT SYSTEM

- ▶ 2 component paints offer a High Level of Corrosion Resistance by combining a base paint and a hardener. The high solid content in 2 component paint creates increased corrosion resistance and durability.





Series ES Ball Valve

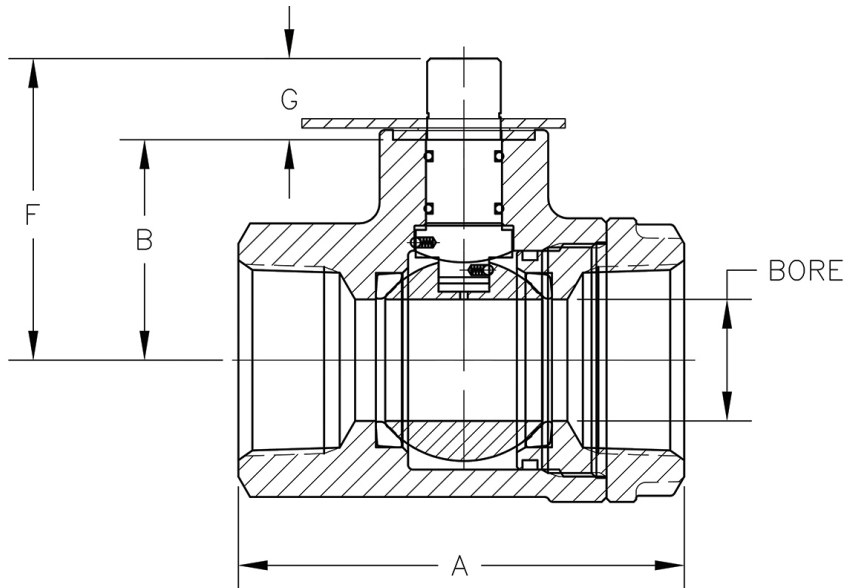

SERIES ES

VALVE	SERIES ES BALL VALVE			
SIZE (in)	1FP 6000	2RP 2000	2RP 3000	2RP 6000
A	4.25	5.50	5.50	5.75
B	1.78	2.72	2.72	2.72
C	.73	.91	.91	.91
D	.465	.636	.636	.636
E	1.55	1.75	1.75	1.75
F	2.72	3.73	3.73	3.73
G	.945	1.05	1.05	1.05
H	6.75	9.5	9.5	9.5
J	1/4	5/16	5/16	5/16
K	1.75	2.00	2.00	2.00
BORE (in)	1.00	1.50	1.50	1.50
VLV WT (lbs)	5.25	11.0	11.0	16.0
HDL WT (lbs)	1.1	1.6	1.6	1.6
CV	60	125	125	125



Series EB Ball Valve

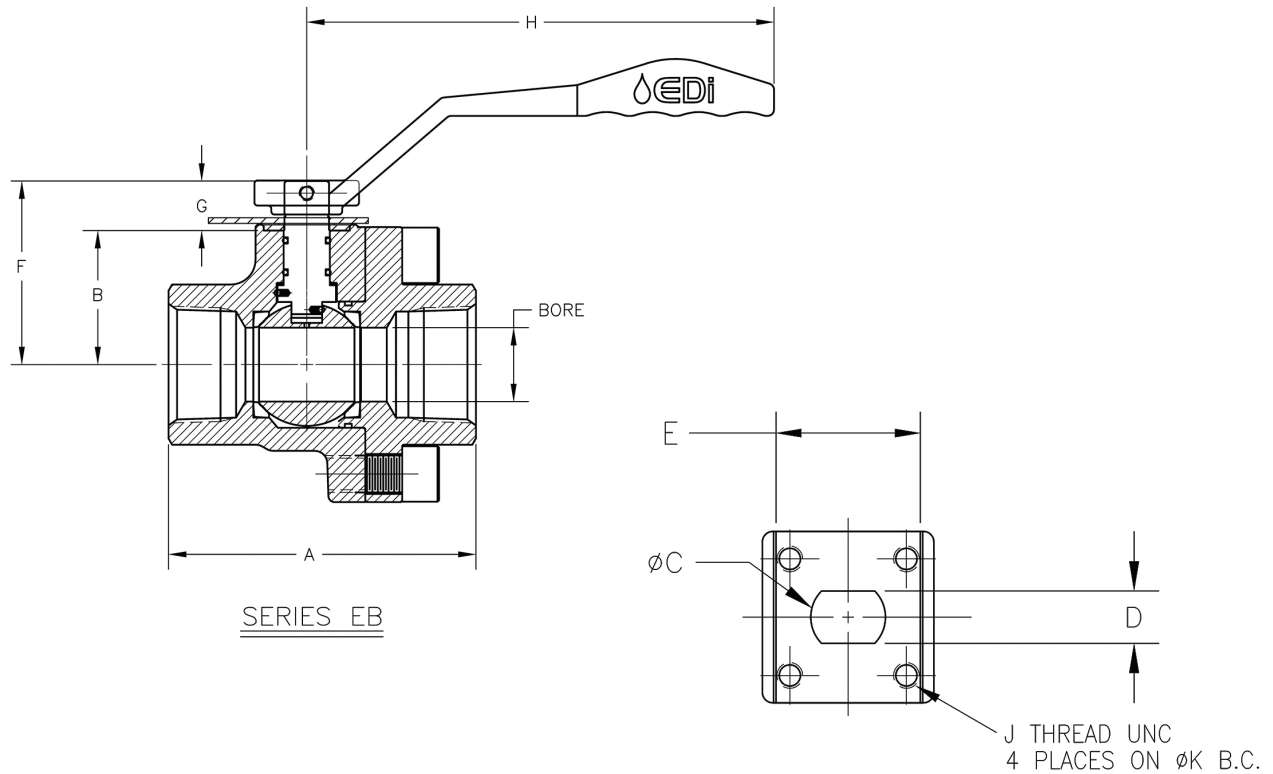

ACTUATOR MOUNTING
DETAIL

VALVE	SERIES EB BALL VALVE							
SIZE (in)	2RP 3000	2RP 6000	2FP 3000	2FP 6000	3FP 2000	3FP 3000	4FP 2000	4FP 3000
A	5.75	6.25	6.25	6.75	8.50	8.50	11.25	11.25
B	2.72	2.72	3.25	3.25	4.48	4.48	5.33	5.33
C	.91	.91	.91	.91	1.360	1.360	1.475	1.475
D	.636	.636	.636	.636	.875	.875	.950	.950
E	1.75	1.75	1.75	1.75	2.375	2.375	2.75	2.75
F	3.73	3.73	4.26	4.26	6.12	6.12	7.03	7.03
G	1.05	1.05	1.05	1.05	1.64	1.64	1.70	1.70
H	9.5	9.5	9.5	9.5	16	16	22	22
J	5/16	5/16	5/16	5/16	3/8	3/8	1/2	1/2
K	2.00	2.00	2.00	2.00	2.75	2.75	3.00	3.00
BORE (in)	1.50	1.50	2.00	2.00	3.00	3.00	4.00	4.00
VLVWT (lbs)	15.5	19	23	30	52	60	92	102
HDLWT (lbs)	1.6	1.6	1.6	1.6	5.0	5.0	8.0	8.0
CV	125	125	360	360	996	996	1893	1893



Part Number Key for EB & ES

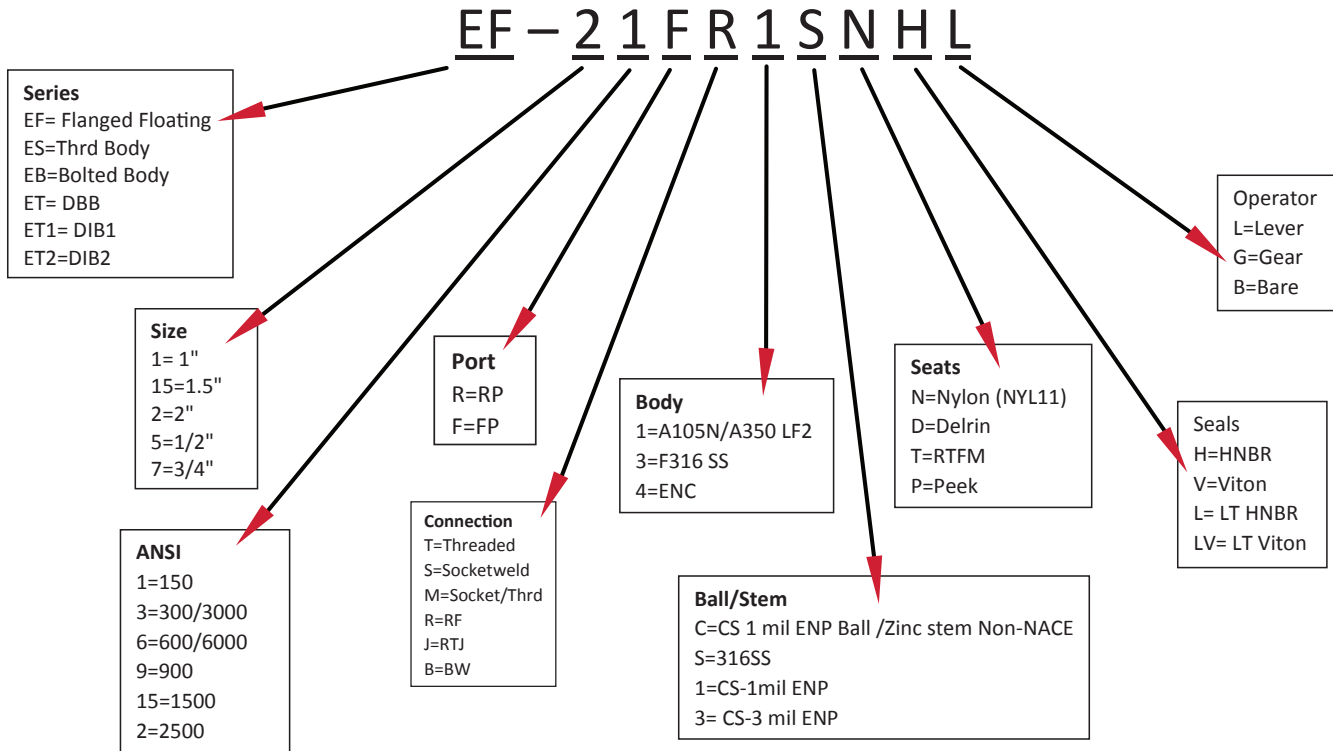



Energy Distribution Innovation

HELPING YOU BUILD THE FUTURE.

www.edivalve.com