



High Performance Floating Ball Valve Series Ef - Flanged

TECHNICAL BULLETIN



EDi PERFORMANCE FEATURES

Forged Bodies and Adapters

Forgings are a fundamental component for producing a High-Performance Floating Ball Valve. Exhibiting increased strength and superior wear resistance, forgings provide enhanced uniformity in grain structure eliminating the possible formation of porosity and cavities that can negatively impact valve performance. EDi bodies and adapters are dual certified ASTM A105 & ASTM A350 LF2 supporting both low and high temperature requirements.

Nylon 11 Seat Material

Nylon 11 is the standard seat material in our High-Performance Floating Ball Valve. Its unique characteristics provide increased dimensional stability and low water absorption in the presence of moisture. The combination of Nylon 11 and EDi's **Progressive Seal Technology™*** also creates significantly low "coefficient of friction" between the ball and seat, resulting in extremely low operating torques. Nylon 11 is well suited to provide enhanced performance in a wide range of Energy and Industrial applications. Alternative seat materials are available as required to support applications better suited to other process environments.

EDi Design Enhancements

EDi High-Performance Floating Ball Valves were developed to far exceed ASME B16.34 Standards. These Enhancements deliver improved durability including:

- ▶ Superior pressure containment with increased wall thickness on forged bodies and adapters. Bolting configurations are designed to exceed ASME B16.34 for both Full and Regular Port valves. Enhanced design to the EDi Full Port valve will also meet or exceed the bolt strength of flow line mating flanges.
- ▶ All EDi High Performance Floating Ball Valves are 100% low pressure and high pressure tested using Pneumatic and Hydrostatic methods, respectively.

Precision Engineered Seals

Precision Engineered Seals and Elastomers provide a wide range of sealing solutions. EDi utilizes U.S. designed and manufactured O-rings and Seals to deliver a High-Performance Floating Ball Valve for the various mediums encountered in Energy and Industrial flow control operations.

State-Of-The ART 2K Paint System

Our High-Performance, two component paint offers an increased level of Corrosion Resistance by combining Polyurethane with a Catalyst. The high solid content and polymer-based system provides a long-lasting corrosion and UV resistance surface with high durability.

*Patent No. US 10,801,626 B2 / International DM/212755



EDi Exploded Valve View

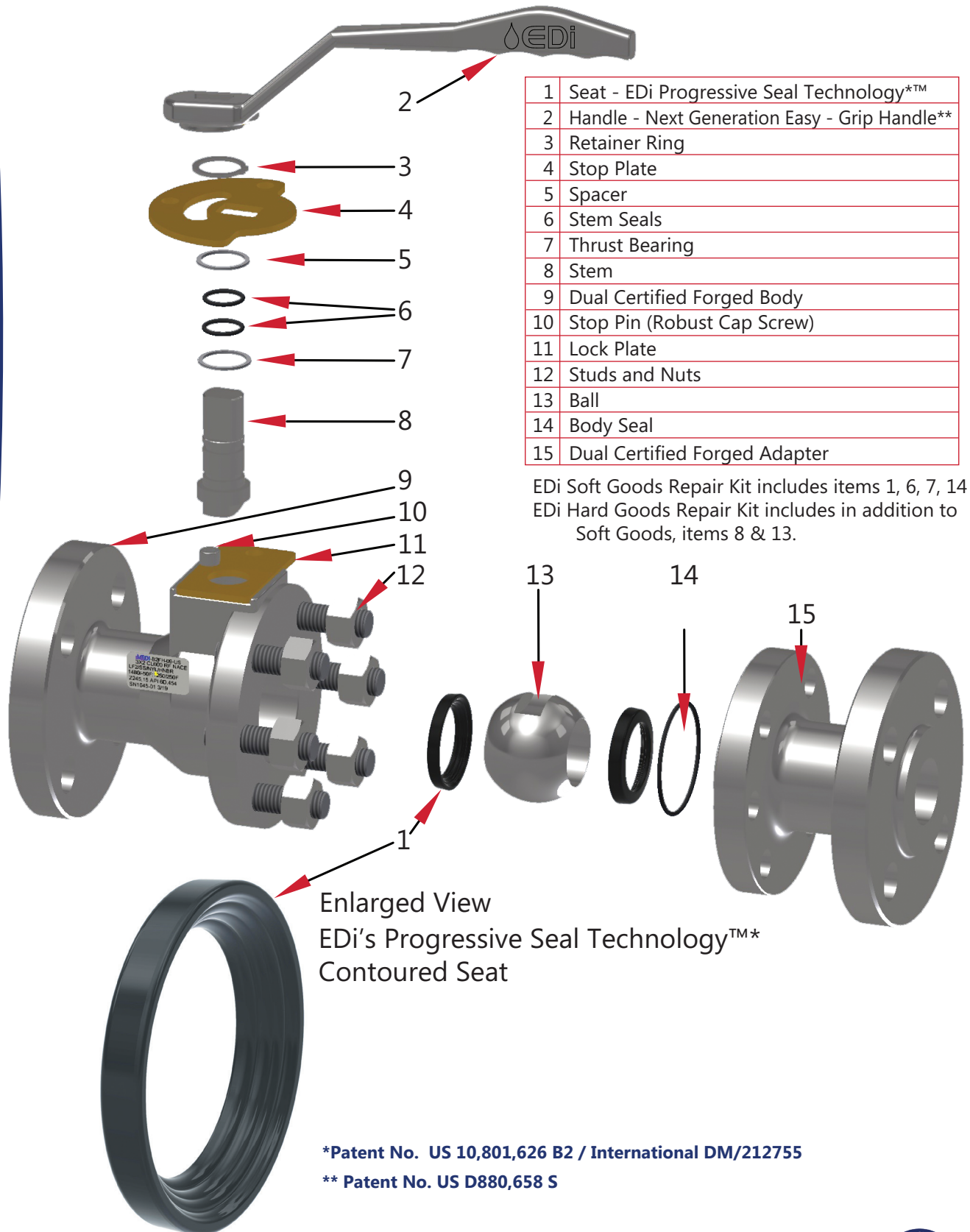



KEY FEATURES

- ▶ Made in USA
- ▶ Buy American Act
- ▶ Made in USA
- ▶ **Progressive Seal Technology™ ***
Evolutionary Seat Design with Enhanced Ball to Seat Interface
- ▶ Forged Bodies and Adapters
- ▶ Every Valve 100% High-Pressure and Low-Pressure Tested
- ▶ Designed and tested to exceed ASME B16.34
- ▶ Advanced Actuator Mounting System Patent Pending
- ▶ Low Torques
- ▶ Robust External Stop Plate System
- ▶ Optimized Stem Shaft Drivetrain System
- ▶ Precision-Engineered Seals
- ▶ Up to CLASS 1500 ANSI Rating
- ▶ Next Generation Easy Grip handle **

EVOLUTION OF THE FLOATING BALL VALVE

EDI has revolutionized the **Floating Ball Valve** with our new Patented **Progressive Seal Technology™ *** design.

The **Original Floating Ball Valve Seat** relies upon an interference fit to compress a solid plastic seal ring. The elastic properties of the plastic resist the induced compression and provide a seal against upstream pressure.

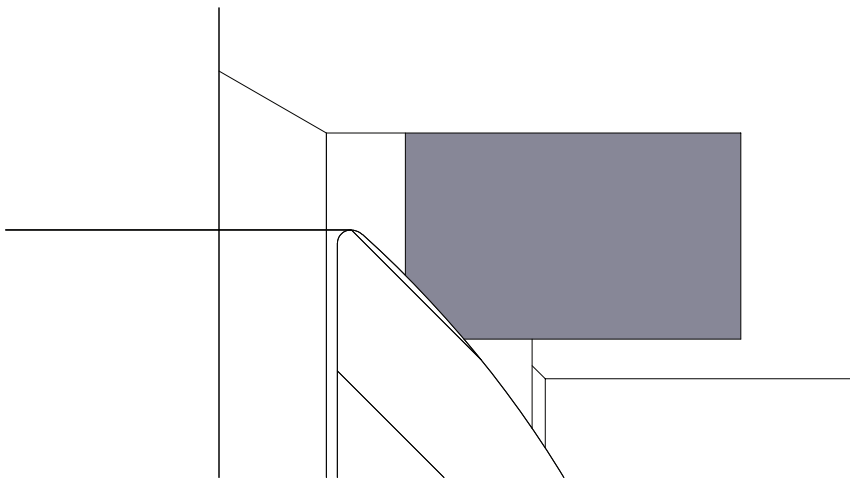

*Patent No. US 10,801,626 B2 / International DM/212755

**Patent No. US D880,658 S



Reliefs added to the **Original Floating Ball Valve Seat** design allowed the seat to react in a more spring like manner advancing seat performance and efficiency.

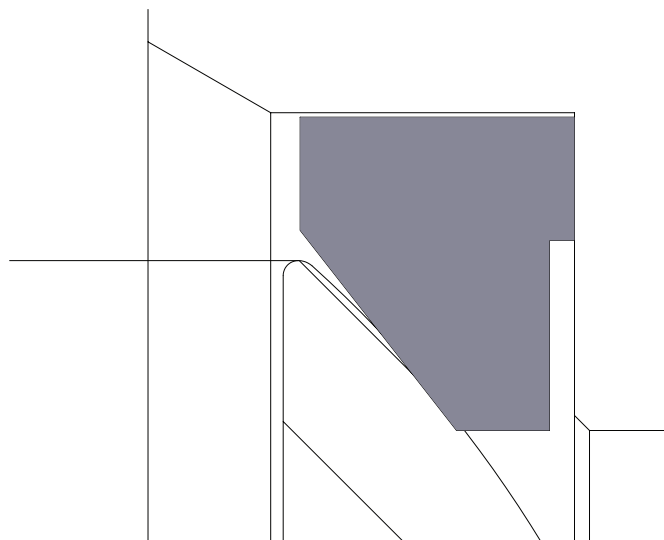

In the late 1960's the introduction of patented **Multi-Seal Technology** continued the advancement of seat design introducing auxiliary blunt edged sealing faces that provided 1 low pressure and up to 2 high pressure sealing contacts. The blunt edged auxiliary faces allowed for grooves to collect and trap particulates for removal over multiple open and close cycles.

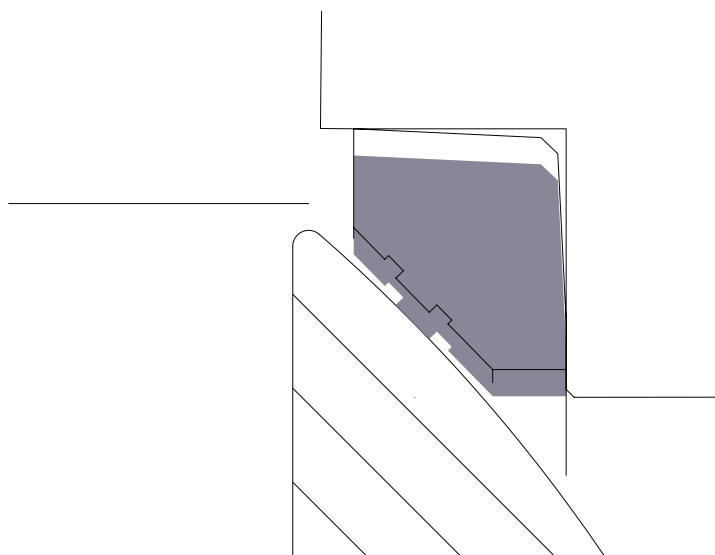

“Operational and Environmental demands challenging the Energy Industry are driving the need for an improved floating ball valve seat design that provides progressive sealing surfaces in both low and high pressure applications ”



Introducing EDi Progressive Seal Technology™ *

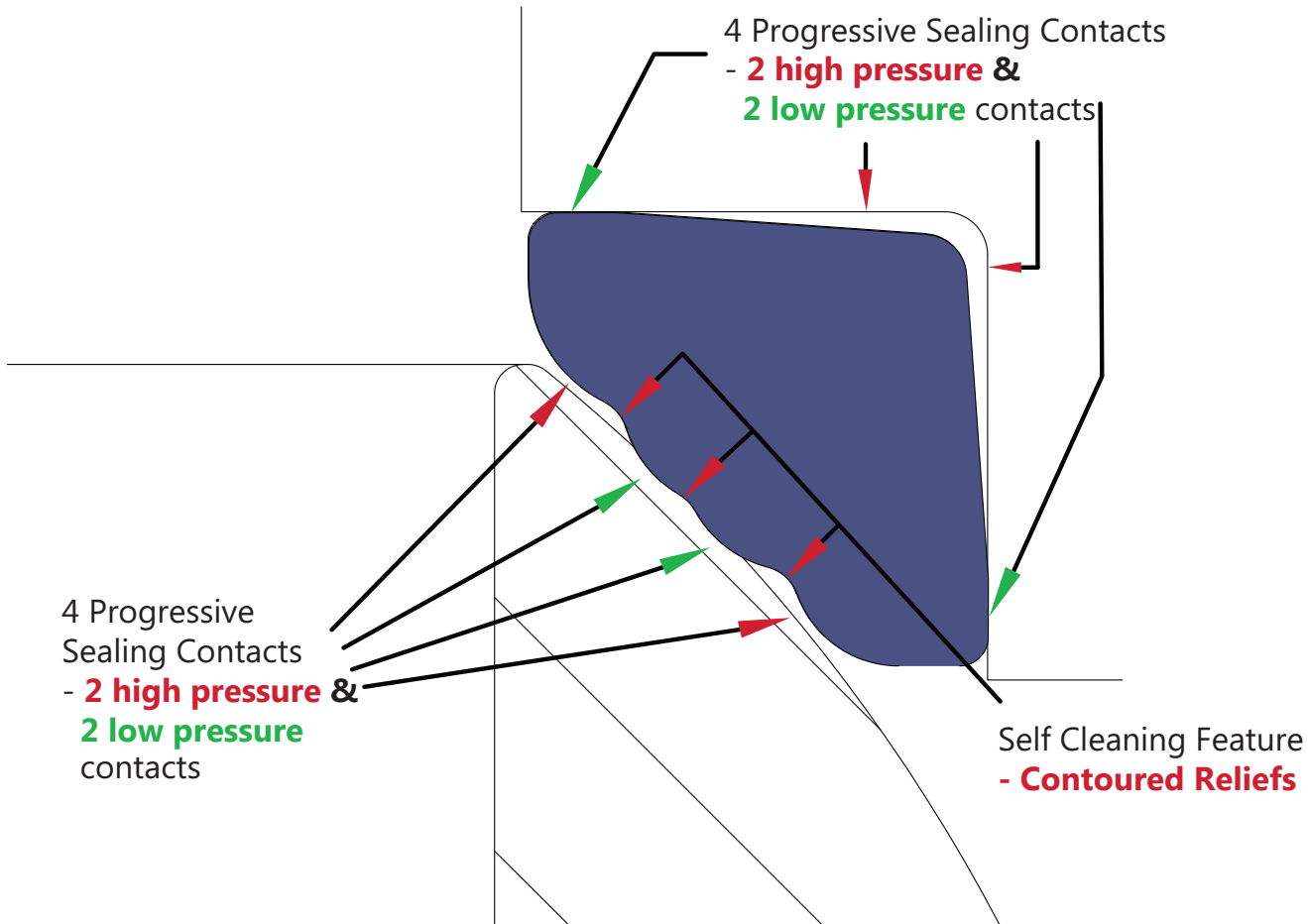

EDi's **Progressive Seal Technology™*** introduces 4 Contoured Front Sealing Faces and 4 Flat Backside Sealing Faces that dramatically improve low and high pressure bubble tight sealing in floating ball valve applications. The dynamically energized seat is designed to be self relieving on the upstream side reducing operating torques.

Seats with blunt-edge grooves can capture and retain particulate during repeated open and close cycles potentially damaging the ball surface. EDi's **Progressive Seal Technology™*** introduces 4 independent seal faces separated by contoured reliefs that ensure particulates are readily swept away during opening and closing cycles.

The 4 Flat Backside Sealing Faces protect the seat pocket from particulate by isolating the seal surface on the backside of the seat ensuring optimum seat performance and efficiency.

EDi's **Progressive Seal Technology™*** offers an evolution in sealing performance that is at the very heart of floating ball valve design. Delivering advanced sealing performance, lower torques, and enhanced operational characteristics, EDi products are at the forefront of valve innovation

*Patent No. US 10,801,626 B2 / International DM/212755



Optimized Stem Shaft Drivetrain System

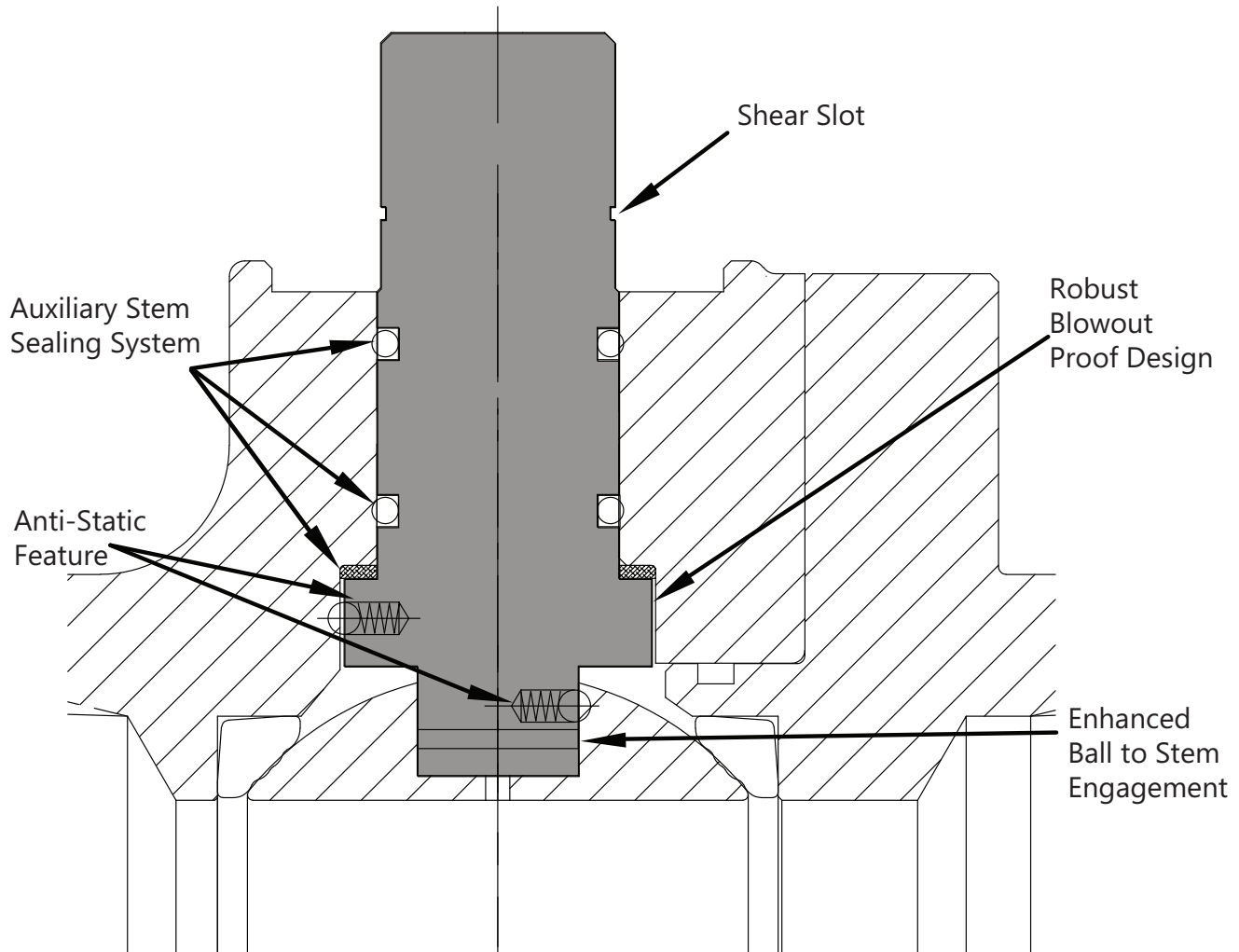

Key Features

- Extra Large Stem for strength, operation and safety
- Enhanced Ball to Stem Engagement
- Auxiliary Stem Sealing
- Integrated Safety Shear Slot
- Anti-Static feature to ensure continuity and eliminate electrostatic discharge



ADVANCED "NEVER SLIP" ACTUATOR MOUNTING SYSTEM Patent Pending

- ▶ Forged integrated Guide Rails
- ▶ Strong Torque Transmission
- ▶ Off the shelf bracketing pre-fabricated to ISO-5211
- ▶ Set it and forget it with Never Slip Design
- ▶ 100% Actuator Ready

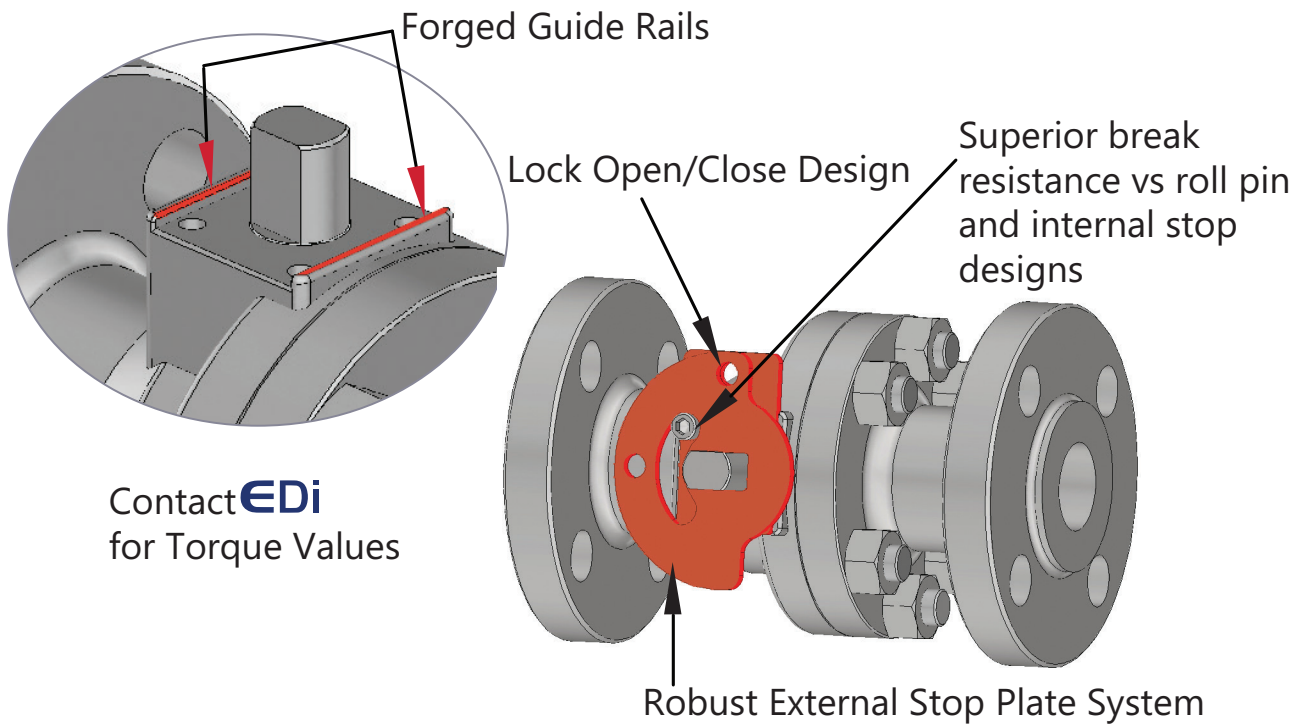

NEXT GENERATION EASY-GRIP HANDLE**

- ▶ Perfect Ergonomics for a more natural fit & support
- ▶ 4 Non-Slip, Form Fitted Gripping Points

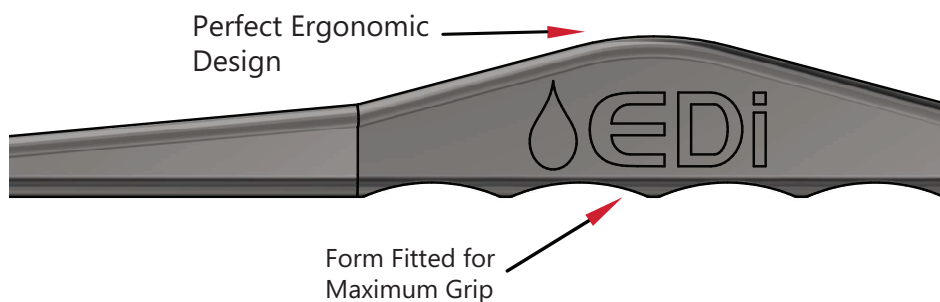

** Patent No. US D880,658 S





Design and Manufacturing Standards

Series Ef

Design & Manufacturing Standards	API 6D/6A/608, ASME B16.34 ASME BPVC Sec. VIII DIV 1 & 2
Flange Connections	B16.5
Valve Bore	API 6D/608
Socket Weld Ends	ASME B16.11
Pressure Tests	API 6D/API 598/ASME B16.34
Fire Safe Design	API 607
NACE Compliance	NACE MR-01-75 / ISO 15156
Quality System	ISO 9001-2015 / Q1
Fugitive Emission Design	ISO 15848-1/API/ANSI/ISA S 93.00.01
Markings	MSS - SP - 25 / ASME B16.34/API 6D
End to End	ASME B16.10
Buttweld Ends	ASME B16.25





Series EF Ball Valve

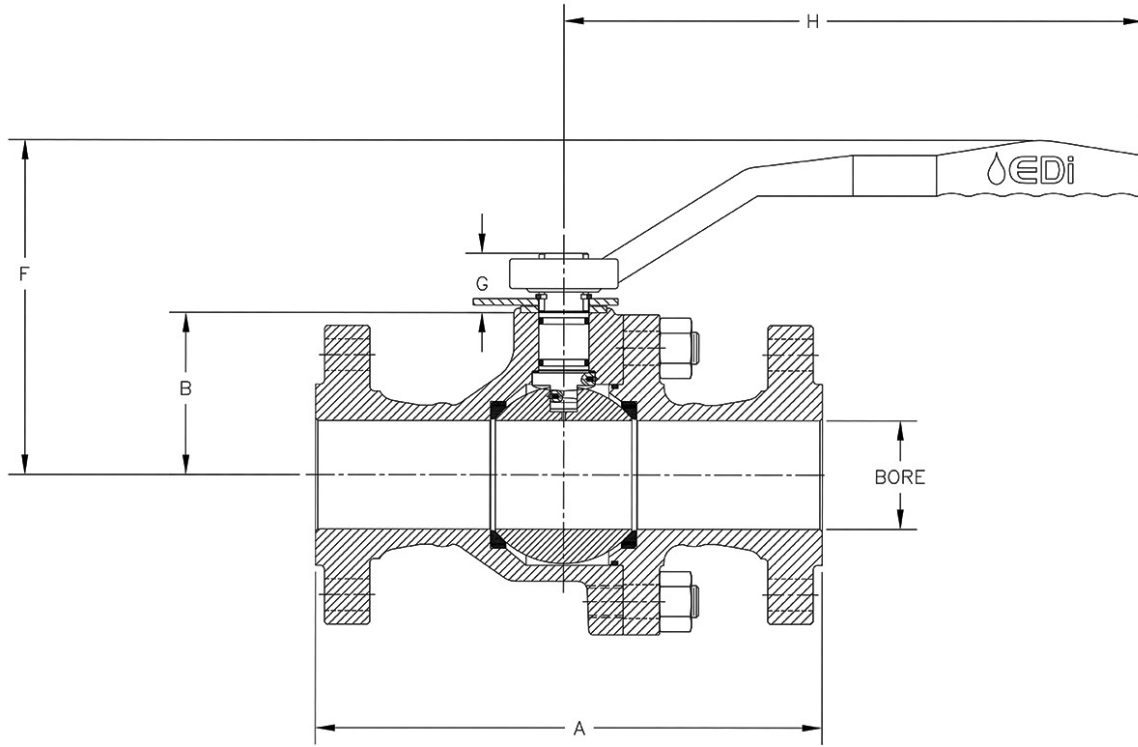

Series EF

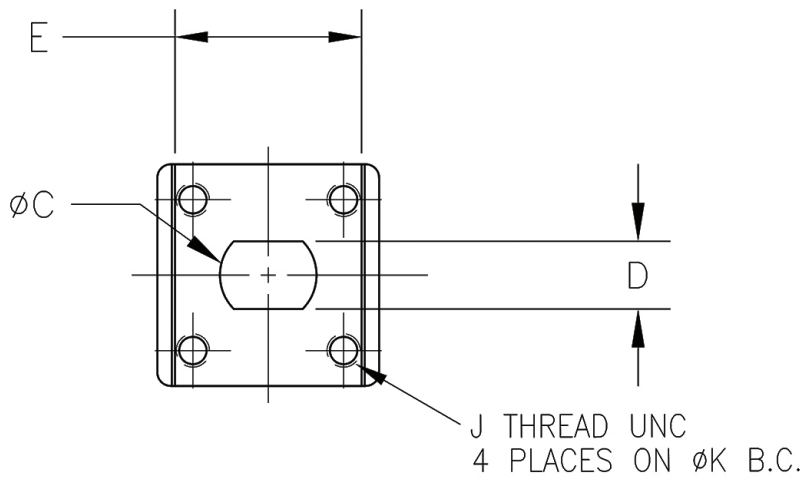

ACTUATOR MOUNTING DETAIL



Series EF Ball Valve

VALVE	SERIES EF BALL VALVE DIMENSIONAL DATA								
	1" FP	1.5" FP	2" RP	2" FP	3" RP	3" FP	4" RP	4" FP	6" RP
SIZE (in)	1" FP	1.5" FP	2" RP	2" FP	3" RP	3" FP	4" RP	4" FP	6" RP
A CL150	5.00	6.50	7.00	7.00	8.00	8.00	9.00	9.00	10.50*
A CL300	6.50	7.50	8.50	8.50	11.12	11.12	12.00	12.00	15.88
A CL600 RF	8.50	9.50	11.50	11.50	14.00	14.00	17.00	17.00	22.00
A CL600 RTJ	8.50	9.50	11.62	11.62	14.12	14.12	17.12	17.12	22.12
B	1.78	2.72	2.72	3.25	3.25	4.48	4.48	5.33	5.33
C	0.73	0.91	0.91	0.91	0.91	1.37	1.37	1.49	1.49
D	0.465	0.636	0.636	0.636	0.636	0.850	0.850	0.960	0.960
E	1.55	1.75	1.75	1.75	1.75	2.38	2.38	2.75	2.75
F	4.72	6.20	6.20	6.75	6.75	9.25	9.25	10.20	10.20
G	0.95	1.05	1.05	1.05	1.05	1.64	1.64	1.70	1.70
H CL150	7.00	9.50	9.50	9.50	9.50	16.00	16.00	16.00	16.00
H CL300	7.00	9.50	9.50	9.50	9.50	16.00	16.00	22.00	22.00
H CL600	7.00	9.50	9.50	9.50	9.50	22.00	22.00	22.00	22.00
J	0.250	0.312	0.312	0.312	0.312	0.375	0.375	0.500	0.500
K	1.75	2.00	2.00	2.00	2.00	2.75	2.75	3.00	3.00
BORE (in)	1.00	1.50	1.50	2.00	2.00	3.00	3.00	4.00	4.00
VLV WT (lbs) CL150	18	23	25	31	48	70	81	105	121
VLV WT (lbs) CL300	24	29	30	36	56	83	96	129	194
VLV WT (lbs) CL600	27	31	36	43	65	99	146	265	392
HDL WT (lbs) CL150	1.1	1.6	1.6	1.6	1.6	6.0	6.0	6.0	6.0
HDL WT (lbs) CL300	1.1	1.6	1.6	1.6	1.6	6.0	6.0	8.0	8.0
HDL WT (lbs) CL600	1.1	1.6	1.6	1.6	1.6	8.0	8.0	8.0	8.0
CV CL150	89	230	137	485	238	1380	635	2580	925
CV CL300	89	215	130	430	220	1220	610	2300	880
CV CL600	70	195	120	406	195	1100	585	2100	800

*Short Pattern



EDI Seat Material Chart

Seat Designation	Chemical Name	Tempature Range for EDi Series EF	EDi Recommended ANSI	Application/Benefits
Nylon 11	Polyamide 11	- 46C (-50F) to 104C (220F)	150 - 600	Nylon 11 has a combination of low water absorption and chemical resistance, resulting in seats with enhanced dimensional stability. The combination of Nylon 11 and EDi's Progressive Seal Technology creates a significantly low "coefficient of friction" between the ball and seat, resulting in extremely Low Operating Torques.
Delrin®	Polyoxymethylene Acetal	- 46C (-50F) to 93C (200F)	600 - 1500	Delrin has a combination of strength, fatigue & abrasion resistance. It can also withstand higher pressures.
RTFM	Modified Polytetrafluoroethylene	- 46C (-50F) to 204C (400F)	150 - 300	High lubricity and sealing capability with superior strength to PTFE.
PTFE	Polytetrafluoroethylene	- 46C (-50F) to 204C (400F)	150 - 300	Standard material with high lubricity and sealing capability.
Devlon®	Polyamide	- 46C (-50F) to 150C (300F)	600 - 1500	Superior pressure / temperature operating range in comparison to PTFE.
PEEK	Polyether ether ketone	- 46C (-50F) to 260C (500F)	150 - 1500	PEEK is recommended for high temperature applications.

Delrin® is a Du Pont registered trademark, Devlon® is a Devol Engineering registered trademark.

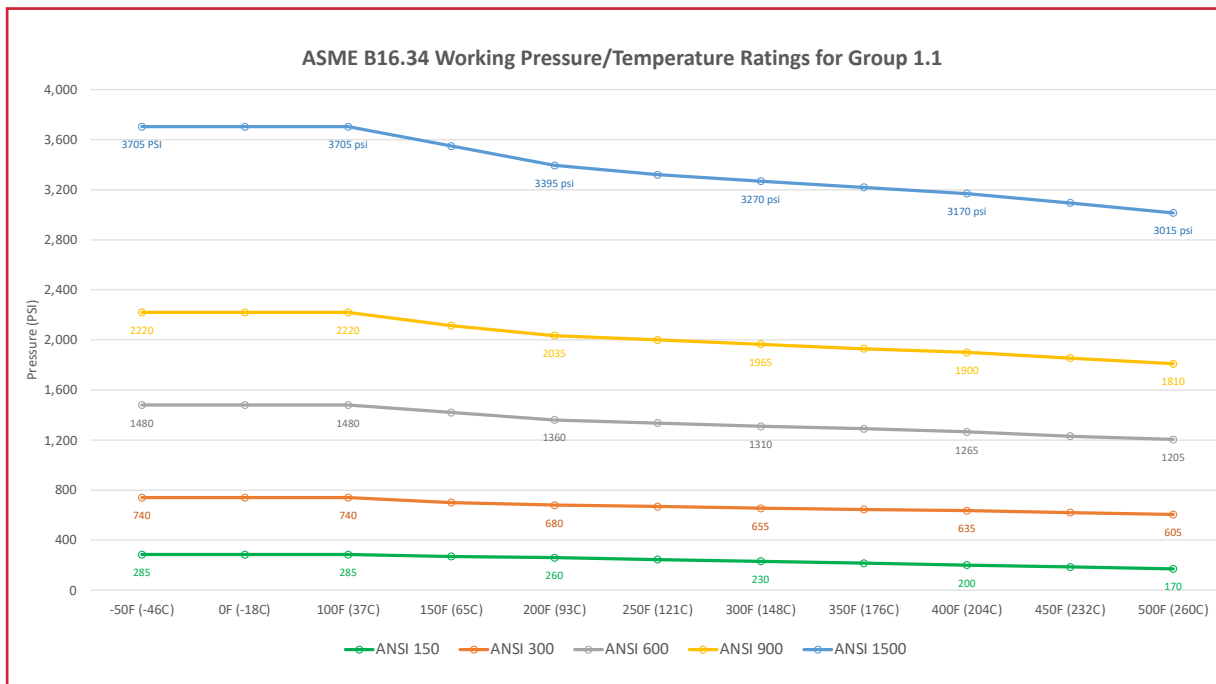



EDi Elastomer Chart

Material	Temp. Range Degrees F/C	H2S	ED Resistant	Key Features
Nitrile Buna - N	-20F to 220F/-29C to 104C	-	NR	Buna-N is a general purpose polymer which has good resistance to oil, water, solvents and hydraulic fluids. It also displays good compression, abrasion resistance, and tensile strength.
Hydrogenated Nitrile (HNBR) 80 Duro	-30F to 300F/-35C to 150C	5-10% max	Good	HNBR rubbers are developed to meet demanding applications and environments. They are known for physical strength and retention of properties after exposure to heat, oil and chemicals.
Hydrogenated Nitrile (Low Temp HNBR) 85 Duro	-55F to 300F/-48C to 150C	5-10% max	Good	Superior mechanical characteristics, particularly high strength, helps reduce extrusion and wear. NORSOK-SNS, ISO 23936-2 North America
Fluorocarbon (FKM) 75	-15F to 400F/-26C to 204C	-	NR	Fluorocarbon elastomers are inherently compatible with a broad spectrum of chemicals.
Fluorocarbon (FKM) 90	-20F to 400F/-29C to 204C	-	NR	Excellent resistance to high temperatures; mineral acids, salt solutions, chlorinated hydrocarbons and petroleum oils, synthetic hydraulic fluids, fuels, aromatics and many organic solvents and chemicals. Gas permeability is very low.
Fluorocarbon 95 Low Temp (FKM)	-50F to 400F/-46C to 204C	10% max	Excellent	Ideal for Critical applications with detrimental effects of explosive decompression (ED) and extrusion. This fluorocarbon material has a unique combination of superior physical and chemical properties. ISO 23936-2 North America
Ethylene Propylene (EPDM)	-50F to 450F/-46C to 232C	35% max	Good	EPDM has good abrasion and tear resistance and offers excellent chemical resistance to a variety of acids and alkalines. It is susceptible to attacks by oils and is not recommended for applications involving petroleum oils, strong acids, or strong alkalines.
AFLAS®	36F to 450F/2C to 232C	35% max	Excellent	Outstanding base resistance (e.g. caustics, alkalines, amines, nucleophiles), and excellent oil resistance.

FAILURE OR IMPROPER SELECTION OR IMPROPER USE OF THE PRODUCTS DESCRIBED HEREIN OR RELATED ITEMS CAN CAUSE DEATH, PERSONAL INJURY AND PROPERTY DAMAGE.

The user, through its own analysis and testing, is solely responsible for making the final selection of the system and components and assuring that all performance, endurance, maintenance, safety and warning requirements of the application are met. The user must analyze all aspects of the application, follow applicable industry standards, and follow the information concerning the product in the current product catalog and in any other materials provided from EDi or its subsidiaries or authorized distributors. To the extent that EDi or its subsidiaries or authorized distributors provide component or system options based upon data or specifications provided by the user, the user is responsible for determining that such data and specifications are suitable and sufficient for all applications and reasonably foreseeable uses of the components.

AFLAS® is a registered trademark of Asahi Glass Company.





Part Number Key for EB & ES

EF - 2 1 FR 1 S N H L

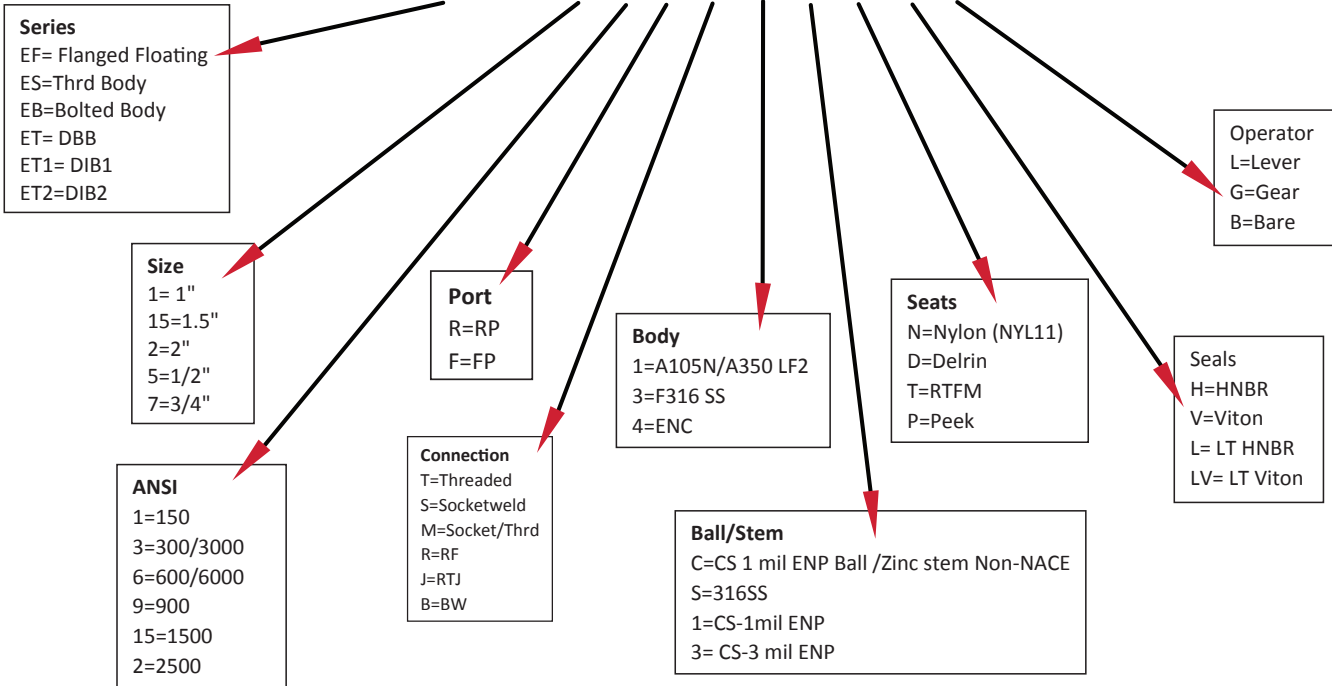



Energy Distribution Innovation

HELPING YOU BUILD THE FUTURE.

www.edivalve.com